

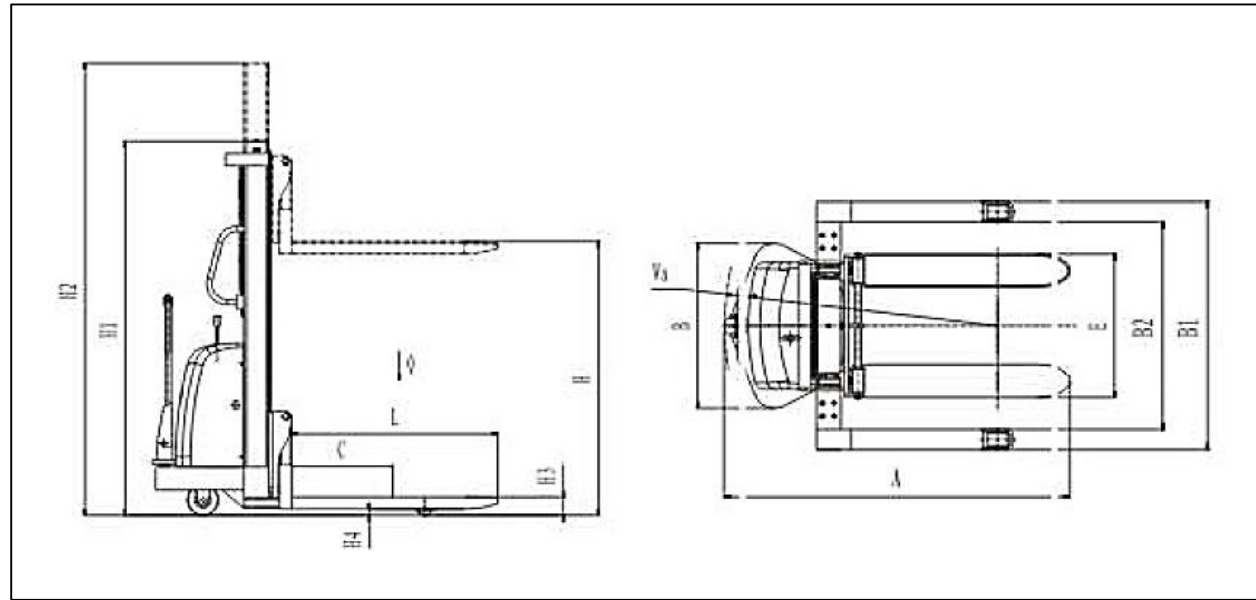

APILADOR SEMI-ELÉCTRICO CON SOPORTES EXTRAS



MODELO	BATERÍA	CAPACIDAD	TIPO DE MÁSTIL	ALTURA DEL MÁSTIL	TIPO DE HORQUILLA	LONGITUD DE HORQUILLAS	DIMENSIONES (L * H * A)
BES1535-G	6DG-220B110A/H	1.5T	DUPLEX	3.5M	FIJA	1250MM	1830 * 2530 * 1550MM