

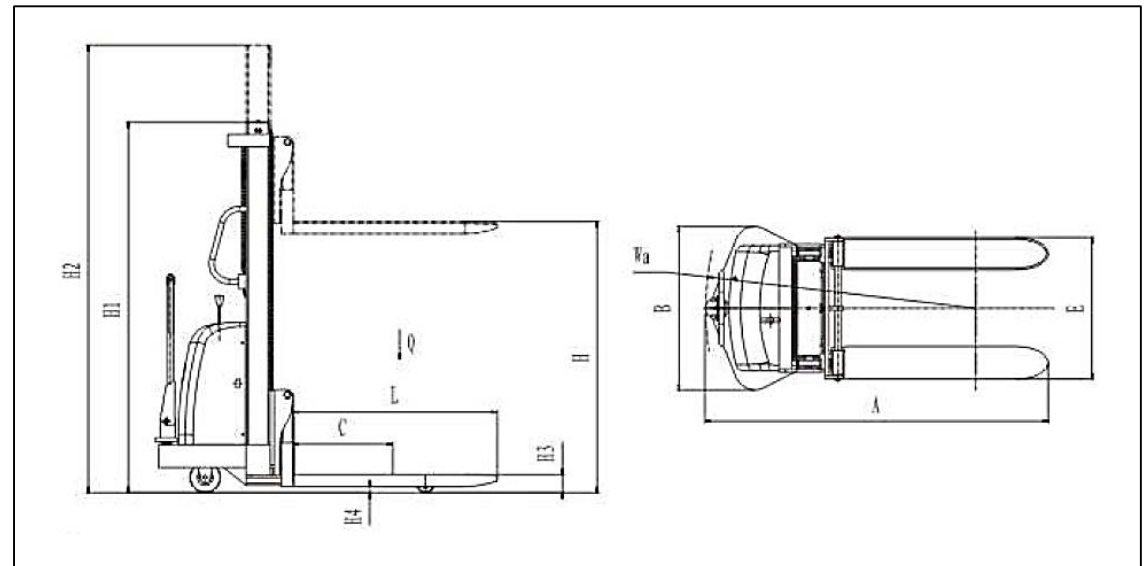

# APILADOR SEMI-ELÉCTRICO ESTÁNDAR



MODELO	BATERÍA	CAPACIDAD	TIPO DE MÁSTIL	ALTURA DEL MÁSTIL	TIPO DE HORQUILLA	LONGITUD DE HORQUILLAS	DIMENSIONES (L * H * A)
BES1535	6DG-220B110A/H	1.5T	DUPLEX	3.5M	FIJA	1150MM	1815 * 2485 * 800MM