

HD 700

DATI TECNICI	TECHNICAL DATA	DONNÉES TECHNIQUES	TECHNISCHE DATEN	DATOS TÉCNICOS	DADOS TÉCNICOS	
Capacità della morsa	Chucking device capacity	Capacité de l'étau	Spannbereich	Capacidad de la mordaza	Capacidade da morsa	14" 26"
Motore centralina	Unit motor	Moteur centrale	Motor aggregat.	Motor de la centralita	Motor da central	1,1 Kw
Motoriduttore	gear box motor	Motoréducteur	Getriebemotor	Motorreductor	Motorreductor	3 Ph 1,5 kw- 1,8 Kw
Capacità sollevamento ruota	Max. wheel lifter capacity	Portée de levage de la roue	Hubkraft Rad	Capacidad elevación rueda	Capacidade de elevação da roda	700 kg
Capacità portata cilindro	Cylinder load capacità	Capacité de portée du vérin	Kapazität Zylinder	Capacidad de carga del cilindro	Capacidade de carga do cilindro	1200 kg

- ACCESSORI STANDARD • STANDARD ACCESSORIES
- EQUIPEMENT DE SÉRIE • STANDARDZUBEHÖR
- ACCESORIOS ESTÁNDAR • ACESSÓRIOS PADRÃO



- ACCESSORI A RICHIESTA • OPTIONAL ACCESSORIES
- EQUIPEMENT SUR DEMANDE • OPTIONALE ZUBEHÖRTEILE
- ACCESORIOS BAJO PEDIDO • ACESSÓRIOS A PEDIDO



- DIMENSIONI DI INGOMBRO • OVERALL DIMENSIONS • DIMENSIONS ENCOMBREMENT
- ABMESSUNGEN • DIMENSIONES TOTALES • DIMENSÕES GERAIS

	min	max
H	970	1220
L	1915	2220
P	1700	2000

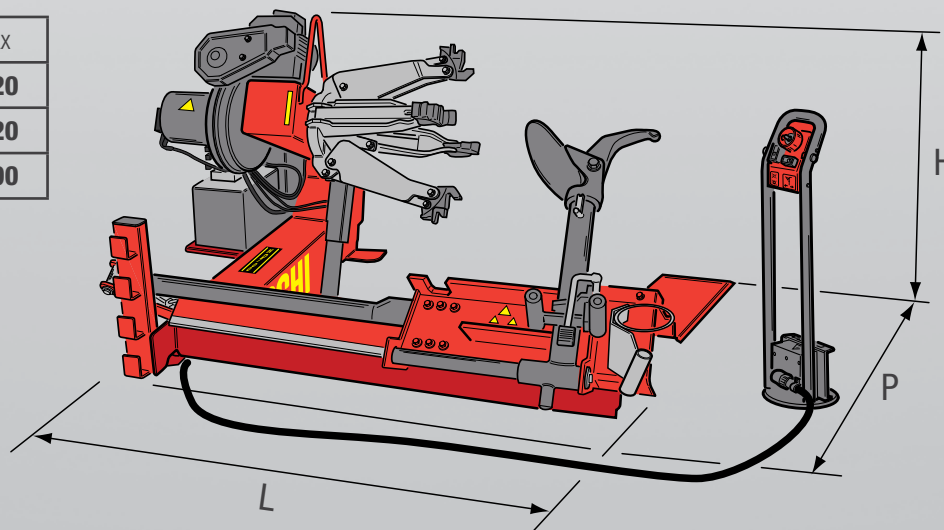

Fotografie, caratteristiche ed i dati tecnici non sono vincolanti, possono subire modifiche senza preavviso. The manufacturer reserves the right to modify the features of its products at any time. Les photographies, les descriptions et les données techniques ne sont pas contraignantes. Le fabricant se réserve le droit d'apporter des modifications sans préavis. Die Fotografien, die angegebenen Eigenschaften und die technischen Daten sind nicht verbindlich und können ohne Vorankündigung geändert werden. Fotos, charakterísticas y datos técnicos no son vinculantes, pueden estar sujetos a modificaciones sin previo aviso. As fotografias, as características e os dados técnicos não são vinculantes, podem ser modificados sem prévio aviso. Code DP66000382 05/2011



Per aiutare il pianeta ottimizzando il consumo di carta, i nostri cataloghi sono consultabili sul sito www.corghicom. Una stampa responsabile aiuta a preservare l'ambiente. To protect the planet and reduce paper usage, our catalogues are viewable online at the website www.corghicom. Printing responsibly contributes to saving the environment.



HD 700

-  Smontagomme elettro-idraulico per ruote di veicoli industriali, camion, e bus da 14" a 26"
La proposta ideale per chi cerca l'essenziale senza rinunciare alla qualità
-  *Electrohydraulic tyre changer for industrial vehicle, truck and bus wheels from 14" to 26"*
The ideal machine for the professional who needs an essential solution but refuses to sacrifice quality
-  Démonte-pneus hydro-électrique pour roues de véhicules utilitaires, camions et bus de 14" à 26"
Il s'agit de la proposition idéale pour ceux qui recherchent l'essentiel sans renoncer à la qualité



-  Elektrohydraulische Reifenmontiermaschine für Räder von Industriefahrzeugen, Lkws und Bussen von 14" bis 26"
Ideal für alle, die das Wesentliche suchen, ohne auf die Qualität verzichten zu wollen.
-  *Desmontadora de neumáticos electrohidráulica para ruedas de vehículos industriales, camiones y autobuses de 14" a 26"*
La propuesta ideal para quien busca lo esencial sin renunciar a la calidad
-  Desmonta pneus electro-hidráulico para rodas de veículos industriais, camião e ónibus de 14" a 26"
A proposta ideal para quem procura o essencial sem abrir mão da qualidade

HD 700



SMONTAGOMME ELETTRIDRAULICO
per pneumatici di autocarri, autobus,
trattori e veicoli di movimentazione terra,
con cerchi a canale o ad anello elastico e
per pneumatici con o senza camera d'aria.



ELECTROHYDRAULIC TYRE CHANGER for
trucks, buses, tractors and earth moving
equipment with groove or elastic ring type
rim wheels and with tubeless or inner tube
type tyres.



DÉMONTÉ-PNEUS ÉLECTRO-HYDRAULIQUE
pour pneus de poids-lourds, tracteurs et
engins de terrassement, avec jantes à
creux ou à anneau élastique, ainsi que pour
pneus avec ou sans chambre à air.



**ELEKTROHYDRAULISCHE
REIFENMONTIERMASCHINE** für Reifen
von LKWs, Autobussen, Traktoren und
Erdbewegungsmaschinen mit Tiefbett- oder
Sprengerringfelgen und für Schlauchreifen
und schlauchlose Reifen.



**DESMONTADORA DE NEUMÁTICOS
ELECTROHIDRÁULICA** para neumáticos
de camiones, autobuses, tractores y
máquinas para movimiento de tierra, con
llantas con canal o de anillo elástico, y
para neumáticos con o sin cámara de aire.



**DESMONTA PNEUS
ELECTROHIDRÁULICO** para pneus de
camiões, ónibus, tractores e máquinas de
movimentação de terras, com jantes de
canal ou de anel elástico e para pneus com
o sem câmara de ar.



1 Manipolatore con comandi ergonomici **1** Control module with ergonomic controls.
1 Manipulateur avec commandes ergonomiques **1** Bediensäule mit ergonomischen Bedieneinrichtungen. **1** Manipolador con mandos ergonómicos **1** Manipulador com mandos ergonómicos

2 Mandrino autocentrante presa da 14" a 26" con **rotazione oraria ed antioraria** **2** Turntable spindle for clamping rim sizes from 14" to 26" with clockwise and **anticlockwise rotation** **2** Mandrin autocentreur avec prise de 14" à 26" à rotation **en sens horaire et anti-horaire** **2** Spannbereich des Spannfüßers

von 14" bis 26" mit **Drehung im und gegen den Uhrzeigersinn** **2** Mandril autocentrante de toma de 14" a 26" con rotación horaria y antihoraria **2** Mandril autocentrante para extracção de 14" a 26" com **rotação horária e anti-horária**

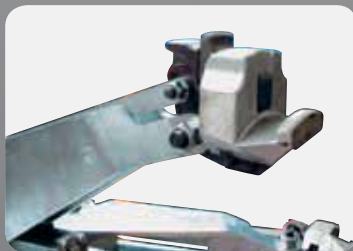

3 Griffe speciali per cerchi in lega con inserti in plastica (a richiesta) **3** Special clamps with plastic insert for alloy rims (optional) **3** Griffes spéciales pour jantes en alliage avec inserts en plastique (sur demande) **3** Spezialspannklauen für Leichtmetallfelgen mit Plasteinsätzen (auf Anfrage) **3** Garras especiales para llantas de aleación con insertos de plástico (bajo pedido) **3** Garras especiais para jantes de liga com aplicações de plástico (sob pedido)

4 Centralina idraulica **4** Hydraulic power unit **4** Centrale hydraulique.
4 Hydraulikaggregat **4** Centralita hidráulica **4** Central hidráulica

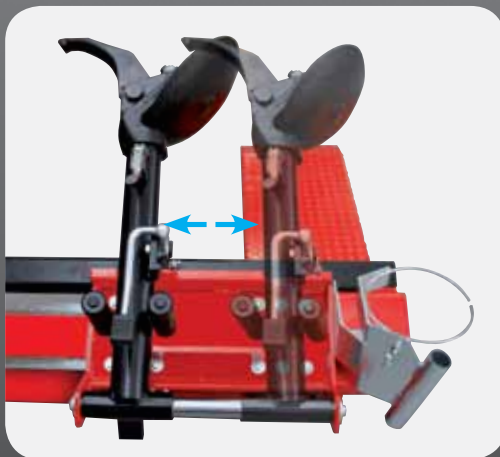

5 Carrello con movimento idraulico destra-sinistra e braccio utensile con sistema di bloccaggio di sicurezza **5** Carriage with hydraulic left-right translation and tool arm with safety lock system **5** Chariot à actionnement hydraulique droite-gauche et bras porte-outil avec dispositif de blocage de sécurité **5** Werkzeugschlitten mit hydraulischer Rechts-Linksbewegung und Werkzeugarm mit Sicherheitsblockiersystem **5** Carro con movimiento hidráulico derecha-izquierda y brazo herramienta con sistema de bloqueo de seguridad **5** Carro com movimento hidráulico direita-esquerda e braço ferramenta com sistema de bloqueio de segurança

6 HD 700 è in grado di operare su ruote di peso fino **700kg** **6** The HD 700 is capable of handling wheels weighing up to **700 KG** **6** HD 700 est en mesure de travailler sur les roues dont le poids va jusqu'à **700KG** **6** Die HD 700 ist in der Lage, an Reifen mit einem Gewicht bis **700 kg ZU ARBEITEN** **6** La HD 700 es capaz de trabajar con ruedas con un peso de hasta **700 kg** **6** HD 700 é capaz de operar em rodas de peso até **700 kg**

